

EL-200

Electronic Rudder control

INSTALLATION & INSTRUCTION

MANUAL

VERSION 3.0
September 2003



SCAN STEERING

Contents

MOUNTING INSTRUCTIONS FOR EL-200 STEERING SYSTEM	3
CONNECTION OF EXTERNAL EQUIPMENT	4
ADJUSTMENT OF EL-200 / SSE200-2	5
DC MEASUREMENT IN CONTROLBOX EL-200	6
SCHEMATIC FOR SSE200-2 PCB	7

MOUNTING INSTRUCTIONS FOR EL-200 STEERING SYSTEM

1. Mount units and connect them number to number and letter to letter. If only steering switch is used shorten 25 and 26.
2. Disconnect terminal 10 and switch on power (24Vdc).
3. When the feedback is adjusted mechanically according to feedback installation, put the rudder in mid-position.

Take out the fuse in the feedback PCB.

Connect E, F and G terminals from auto pilot/rudder control to E, F and G on the feedback PCB.

Turn on the rudder control.

Check that the voltage on E is app. +8V DC (measured between E(+) and G(-)).

Mount the fuses.

Adjust the midpoint of the feedback (mechanical zero) to half voltage (means that the voltage between F and G must be half of the voltage between E and G). So it must be between 3.8V and 4,0V. The mid-point adjustment are done by loosen the screws which hold the top of the feedback and adjust the shaft until the above mentioned voltage is reached.

Check the voltage between F and G (minus on G), when the rudder is turned hard-over to hard-over. At increasing voltage the rudder must turn to starboard . If the feedback works opposite, the jumper on the PCB must be moved (see feed back installation).

Electrical fine adjustment

On the feedback PCB there is possibility of adjustment of GAIN (potentiometer R13) and mid-position (ZERO potentiometer R14).

If the feedback system do not have the necessary sensitivity, adjust GAIN (potentiometer R13) at Hard PORT = 0.75 -1V and hard STBD. = 7 - 7.25 V (measured on F, minus on G)

After adjusting GAIN, ZERO-potentiometer must be adjusted to half voltage F(+) G(-) (with rudder in mid-position).

4. Turn rudder starboard and check that voltage in "F" increases. If "F" decreases then move jumper to the other position in the FBH-amplifier (see FBH-installation)
5. Connect terminal 10 and check that rudder turns starboard, when steering switch is activated starboard. If the rudder goes opposite, exchange the wires in terminal 9 and 11.
6. Rudder limits are adjusted starboard with 'RV1' and port with 'RV2'. Turned clockwise allows greater rudder movements. (See also adjustments page 5)
7. If Full-follow-up (FFU) or hand steering (SH) is used, adjust sensitivity so that system does not 'hunt'. Turn 'RV3' and 'RV4' counter-clockwise simultaneously till system starts hunting, and then turn them a little bit clock-wise until hunting stops.
8. Rudder angle indication can be adjusted inside the indicator (see manual for Rudder indicator)

CONNECTION OF EXTERNAL EQUIPMENT

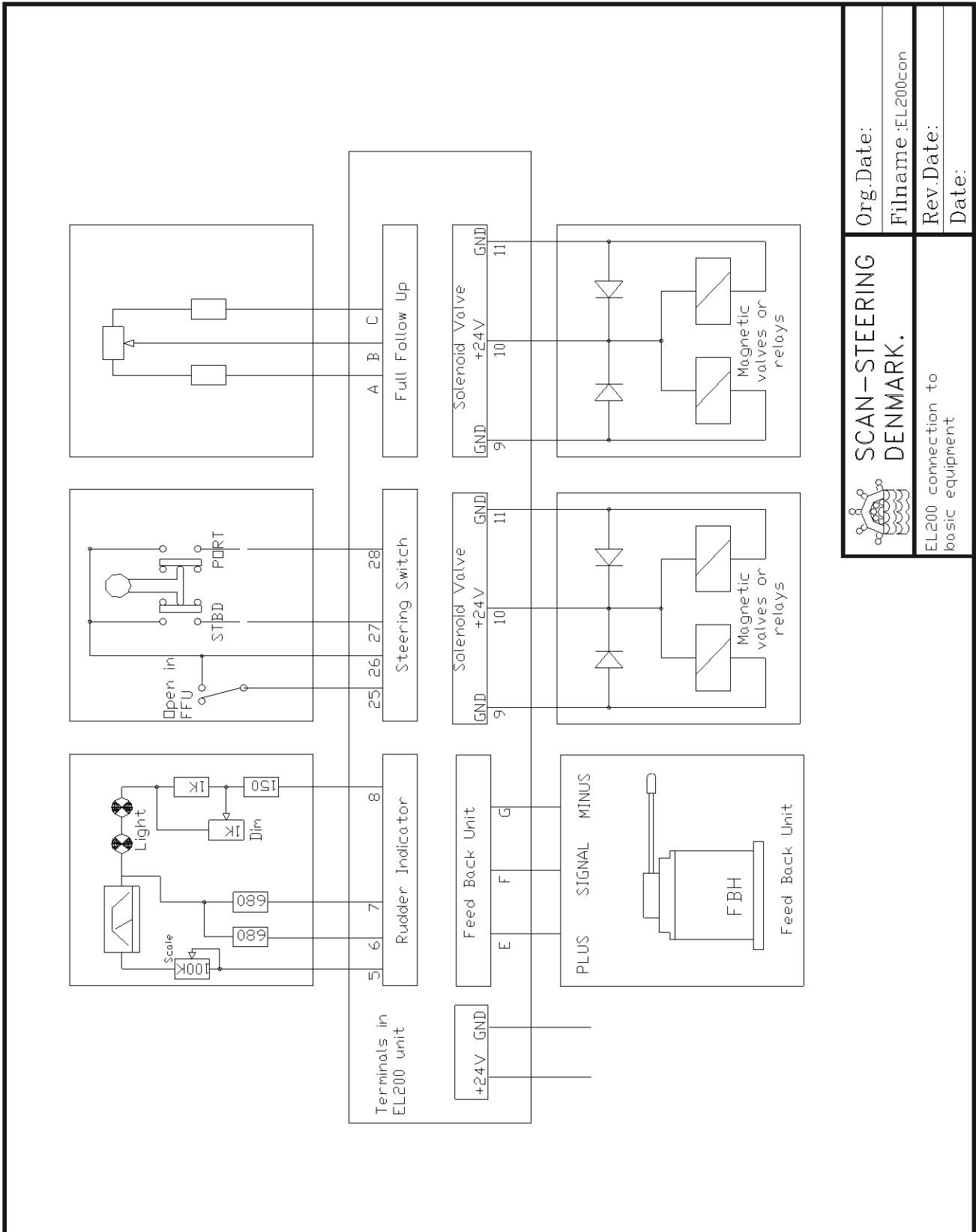

 <p>SCAN-STEERING DENMARK.</p>	Org.Date:
	EL200 connection to basic equipment
	File: EL200.con
	Rev.Date:
	Date:

ADJUSTMENT OF EL-200 / SSE200-2

1. Adjustment of rudder limits RV1 and RV2.
RV1 stops the rudder in starboard – clockwise (CW) gives more deflection.
RV2 stops the rudder in port - clockwise (CW) gives more deflection.
2. Adjustment of sensitivity RV3 and RV4.
Clockwise (CW) gives less sensitivity.
3. Adjustment of full-follow-up (FFU) gain on RV5. Clockwise gives maximum sensitivity (smaller turn on FFU for max. rudder deflection).

Turn FFU-unit to maximum and trim RV5 until rudder deflection reaches the rudder limit. This adjustment works for both starboard and port deflection.

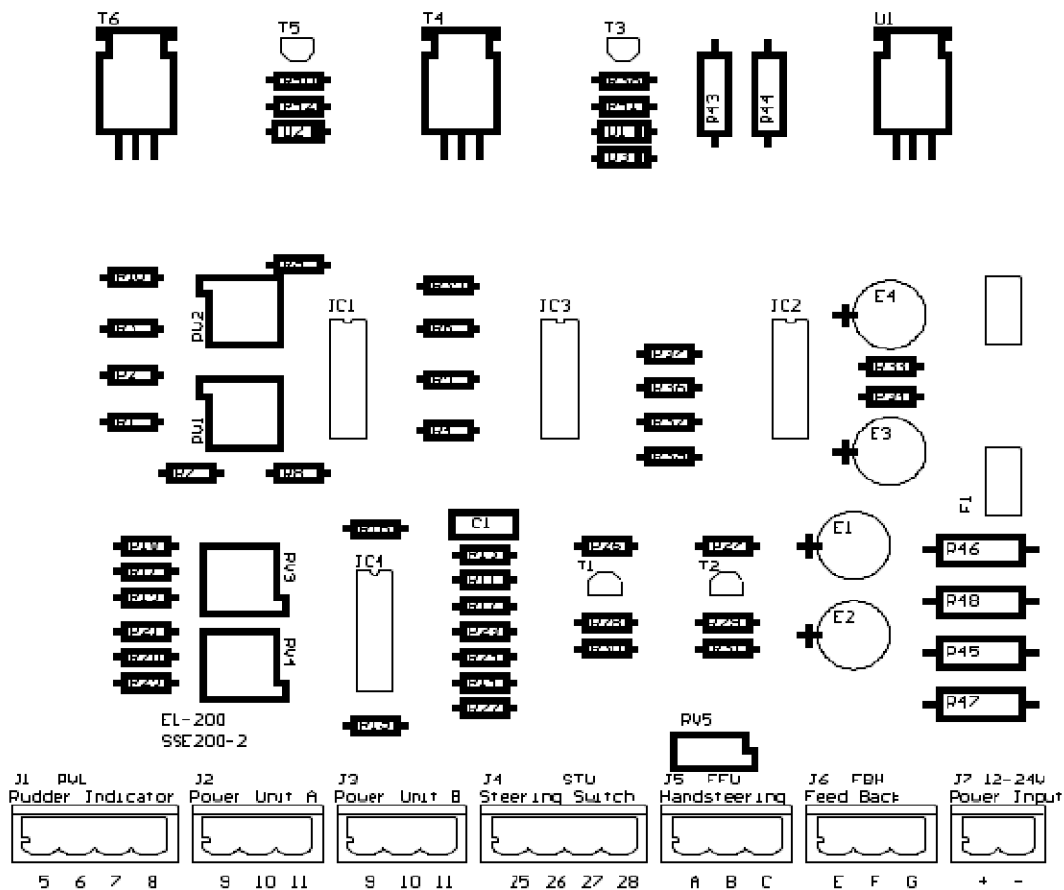

DC MEASUREMENT IN CONTROLBOX EL-200

5. Varying DC, 4 V when rudder in mid-position, raising voltage when rudder at starboard side.
6. + 8 Vdc
7. 0 V
8. + 24 Vdc
9. + 24 Vdc , falling to ca. 1 V when starboard valve is on.
10. + 24 V
11. + 24 V i DU, falling to ca. 1 V when port valve is on.
25. Minus (negativ)
26. Minus (negativ) when PILOT/SWITCH is in "SWITCH" position.
27. Minus (negativ) when in "SWITCH" position, and tiller is pushed to starboard.
28. Minus (negativ) when in "SWITCH" position, and tiller is pushed to port.
- A. + 8 V
- B. Input from Full follow up
- C. Minus (negative)
- E. + 8 V
- F. As terminal 5.
- G. Minus (negative)
- + Power supply for EL-200 unit.
-

SCHMATIC FOR SSE200-2 PCB

